

# EARTH CLAMP TESTER

**FR2000+**  
**FR2000C+**

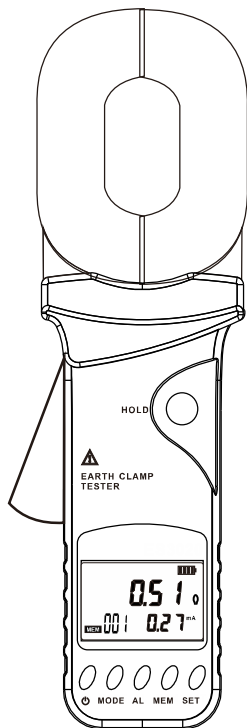

## User Manual

Guangzhou Zhengneng Electronic Technology Co.,Ltd

# CONTENT

I. Safety Precautions and Procedures.....	2
II. Brief Introduction .....	4
III. Range and Accuracy .....	5
IV. Technical Specifications .....	5
V. Structure of Meter .....	8
VI. LCD Display .....	9
VII. Measuring Principle .....	11
VIII. Operation Method .....	12
1.Boot Up .....	9
2. Battery Voltage Check.....	10
3. Resistance Current or Grounding Voltage Test .....	11
4. Alarm Settings .....	11
5. Date Lock .....	15
6. Data Storage / Review / Delete .....	15
IX. Battery Instructions .....	16
X. Field Application .....	16
XI. Accessories .....	22

## I . Safety Rules and Precautions

Thank you for purchasing our company's **clamp grounding resistance tester**. Before using the instrument for the first time, in order to avoid possible electric shock or personal injury, please be sure to: **read and strictly observe the safety rules and precautions listed in this manual.**

In any case, use this instrument should pay special attention to safety

- 2 The instrument is designed, produced and inspected according to IEC61010 safety specifications.
- 2 In any case, the use of this instrument should pay special attention to safety.
- 2 When measuring, high-frequency signal generators such as mobile phones should not be used next to the meter to avoid errors.
- 2 Pay attention to the text and symbols on the body of the instrument.
- 2 Before use, make sure that the instrument and accessories are in good condition before use.
- 2 Before starting the machine, press the trigger once or twice to ensure that the jaws are closed properly.
- 2 Do not measure in a flammable place. Sparks may cause an explosion.

- 2 **Do not withhold the trigger and do not clamp any wires when turning on the meter**
- 2 After the power is turned on normally, the "OL  $\Omega$ " symbol is displayed, and the measured object can be clamped.
- 2 Do not place and store the instrument for a long period of time under conditions of high temperature, humidity, condensation, and direct sunlight.
- 2 When replacing the battery with the meter, make sure the meter is turned off.
- 2 The instrument displays the battery voltage low symbol "", should replace the battery in time, otherwise it will lead to ground error.
- 2 The jaw contact surfaces must be kept clean and cannot be wiped with corrosives and rough objects.
- 2 When opening the trigger, avoid the impact of the clamp, especially the jaw joint.
- 2 When the clamp meter measures the resistance, the clamp head will make a slight noise, which is normal. Note the "deep-beep-beep--" sound that distinguishes the alarm.
- 2 Pay attention to the measuring range and use environment specified by this instrument.
- 2 Do not measure the lead current above the upper limit of the clamp meter.
- 2 The use, disassembly, calibration and maintenance of this instrument must be performed by authorized personnel.

- 2 Because of the reason of this instrument, if it is dangerous to continue using it, it should be immediately stopped and sealed immediately, and it should be handled by a qualified organization.
- 2 The "⚠" safety warning sign in the instrument and manual must be operated strictly in accordance with the contents of this manual.

## II . Brief Introduction

**Clamp ground resistance tester**, also known as **loop resistance tester**, is used to test grounding resistance. The instrument uses a new black luxury screen design, resistance and current display in the same screen, and also has data storage, data access, alarm, automatic shutdown and other functions. The machine is beautiful and upscale, has a wide range, high resolution, convenient operation, easy to carry, accurate, reliable, stable performance, strong anti-interference ability. Moreover, it has a shockproof, dustproof, moisture-proof structure and is a commonly used and indispensable instrument for telecommunications, electricity, meteorology, computer rooms, oil fields, electromechanical installation and maintenance, and industrial enterprises that use electricity as industrial power or energy. It is suitable for measuring various grounding resistances such as telecommunications, electricity, meteorology, computer

rooms, oil fields, power distribution lines, transmission lines of iron towers, gas stations, factory grounding networks, and lightning rods.

The **clamp ground resistance tester** is controlled by the microprocessor and can accurately detect the ground resistance. It uses a fast filtering technique to minimize interference. At the same time data storage and data upload functions

### III . Range and Accuracy

#### 1. Ranges and Accuracy of Measurement

Mode	Range	Resolution	Accuracy
Resistance	0.010Ω-0.099Ω	0.001Ω	± (1%+0.01Ω)
	0.10Ω-0.99Ω	0.01Ω	± (1%+0.01Ω)
	1.0Ω-49.9Ω	0.1Ω	± (1%+0.1Ω)
	50.0Ω-99.5Ω	0.5Ω	± (1.5%+0.5Ω)
	100Ω-199Ω	1Ω	± (2%+1Ω)
	200Ω-395Ω	5Ω	± (5%+5Ω)
	400-590Ω	10Ω	± (10%+10Ω)
	600 Ω -880 Ω	20 Ω	± (20%+20 Ω)
	900 Ω -1200 Ω	30 Ω	± (25%+30 Ω)
Current	0.00mA -9.95mA	0.01mA	± (2.5%+1mA)
	10.0mA -99.0mA	0.1mA	± (2.5%+5mA)
	100mA -300mA	1mA	± (2.5%+10mA)
	0.30A-2.99A	0.01A	± (2.5%+0.1A)
	3.0A-9.9A	0.1A	± (2.5%+0.3A)
	10.0A-20.0A	0.1 A	± (2.5%+0.5A)

## IV. Technical Specifications

<b>Functions</b>	Ground resistance test, Loop resistance test, Leakage Current Test
<b>Ambient Temperature and Humidity</b>	23°C ±5°C, below 75%rh
<b>Power Supply</b>	DC 6V (4 AA alkaline dry batteries)
<b>Range</b>	FR2000+ Resistance: 0.01-500 Ω FR2000C+ Resistance: 0.01-1200 Ω
	FR2000C+Current: 0.00mA-20.0A
<b>Measure Method</b>	Mutual induction
<b>Resistance Resolution</b>	0.001 Ω
<b>Current Resolution</b>	0.01mA
<b>Jaw Size</b>	55mm×32mm
<b>Ω + A simultaneous display</b>	Ω + A simultaneous display
<b>Ground voltage measurement function</b>	No
<b>Display Mode</b>	4-digit LCD display, black screen design
<b>LCD Size</b>	46mm×29mm
<b>Meter Size</b>	L/W/H: 285mm×85mm×58mm
<b>Measure Time</b>	2times/second
<b>Data Storage</b>	300 groups, "MEM" storage indication, display "FULL" symbol indicates that storage is full
<b>Data Review</b>	"MR" symbol indicates when looking up data

<b>Overflow display</b>	"OL" symbol indicates over-range overflow
<b>Interference Test</b>	Automatically identify interference signals, the "NOISE" symbol indicates when the interference current is large
<b>Alarm Function</b>	Alarm when the measured value exceeds the alarm setting value
<b>Battery Voltage</b>	Real-time display of battery power, reminding timely charging when battery voltage is low
<b>Automatic shut-down</b>	Turn off after 5 minutes
<b>Power Consumption</b>	50mA Max
<b>Weight</b>	Meter: 1180g (including battery)
<b>Working Temperature and Humidity</b>	-10℃~40℃; below 80%rh
<b>Storage Temperature and Humidity</b>	-20℃~60℃; below 70%rh
<b>Insulation Resistance</b>	Above 20M $\Omega$ (500V between circuit and case)
<b>Pressure resistance</b>	AC 3700V/rms(between circuit and case)
<b>External Magnetic Field</b>	<40A/m
<b>External Electric Field</b>	<1V/m
<b>Suitable for Safety Regulations</b>	IEC61010-1(CAT III 300V、CAT IV 150V、Pollution degree2); IEC61010-031; IEC61557-1(earth resistance);

## V. Structure of Meter



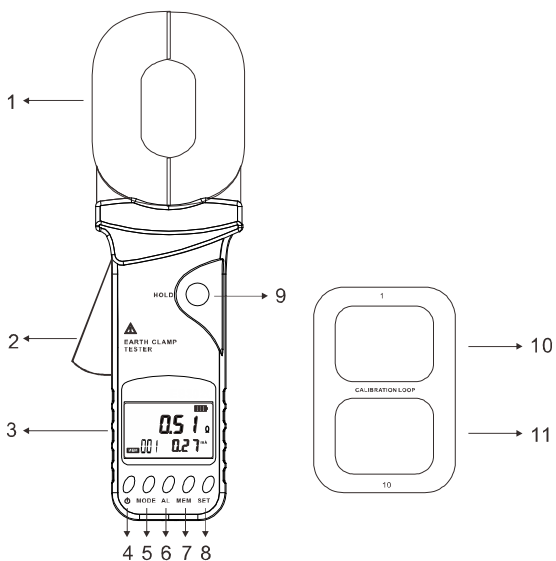

- |                                 |                    |                                 |
|---------------------------------|--------------------|---------------------------------|
| <b>1. Clamp Jaw</b>             | <b>2. Trigger</b>  | <b>3. LCD</b>                   |
| <b>4. POWER Key</b>             | <b>5. MODE Key</b> | <b>6. AL Alarm Function Key</b> |
| <b>7. MEM Key</b>               | <b>8. SET Key</b>  | <b>9. HOLD Key</b>              |
| <b>10. CALIBRATION LOOP:1Ω</b>  |                    |                                 |
| <b>11. CALIBRATION LOOP:10Ω</b> |                    |                                 |

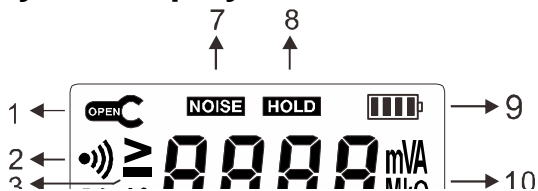

## VI. Liquid Crystal Display



- (1). Jaw Open Symbol
- (2). Alarm Symbol
- (3). Symbol of Greater Than
- (4). DC AC Symbol
- (5). Symbol of data access
- (6). Symbol of data memory
- (7). Noise signal
- (8). Data lock symbol
- (9). Symbol of battery
- (10). Resistance unit
- (11). 4-digital LCD figures display
- (12). Current unit
- (13). 2-Digital No. Of Data Storage Unit
- (14). 4-digital LCD current and clock display

## **Description of Special Symbols**

- (1) .  Symbol of an open jaw: As a jaw is in the open state, the symbol shows. At this point, trigger may be artificially pressed, or the jaws have been seriously polluted, and can no longer continue to measure.

- (2) . **"Er"** Boot-strap error symbol, May be pressing trigger or jaw has been opened when the power is turn on.
- (3) .  Symbol of low battery voltage: when the battery voltage is lower than 5.2V, the symbol shows, it cannot guarantee accuracy of the measurements. Batteries should be replaced.
- (4) . **"OL Ω"** symbol indicates that the measured resistance has exceeded the upper limit of the Meter.
- (5) . **"L0.01Ω"** symbol indicates that the measured resistance has exceeded the lower limit of the Meter.
- (6) . **"OL A"** symbol indicates that the measured current has exceeded the upper limit of the Meter.
- (7) .  Alarm symbol: when the measured value is greater than the critical value of alarm setting, the symbol flashes, and the meter issued by intermittent "beep--beep –beep--" sound.
- (8) . **MEM** Symbol of data storage, flashing when saving data
- (9) . **MR** Review data symbol, display when viewing data, and display the number of stored data at the same time.
- (10) . **NOISE** symbol: This symbol flashes when there is a large interference current in the ground loop being tested. At the same time, the instrument sounds a “beep-beep-beep-” prompt. At this point, the accuracy of the test cannot be guaranteed.

## VII. Measuring Principle

The basic principle of the ground resistance measurement of the clamp-type grounding resistance meter is to measure the

loop resistance. See below. The jaw section of the clamp meter consists of a voltage coil and a current coil. The voltage coil provides the excitation signal and induces a potential  $V$  on the circuit under test. Under the action of the potential  $V$ , a current  $I$  will be generated in the circuit under test. The clamp meter measures  $V$  and  $I$  and uses the following formula to obtain the measured resistance  $R$ .

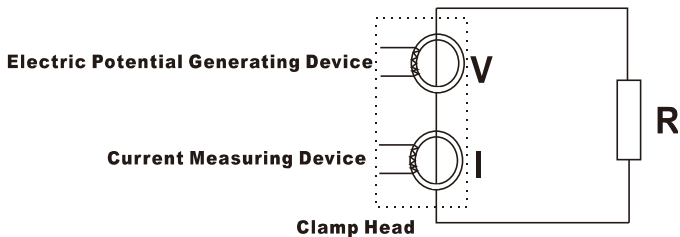

$$R = V / I$$

## VIII. Operation Method

### 1.Boot up

	<b>Boot , DO NOT press the trigger, don't open jaws, nor clamp any wire</b>
	<b>Boot complete, show "OL Ω", then press the trigger, open jaws, clamp the measured wire</b>
	<b>Before booting up, the trigger should be pressed for a couple of times to ensure the jaws are well closed.</b>
	<b>Boot, must maintain clamp meter natural resting state, don't flip Clamp, don't be imposed outside</b>

<b>force on the jaw, otherwise can not guarantee the accuracy of measurement</b>
--

Press the power button to switch on and off. The instrument is automatically calibrated when it is turned on. When the power is turned on, “OL $\Omega$ ” is displayed and the resistance measurement mode is automatically entered. If there is no normal self-calibration, the instrument will display the “Er” symbol to indicate that the power-on error occurs. The common cause of the power-on error is that the jaws are not closed properly、 plunge the wires etc. when starting up.

5 minutes after power on automatically shut down, before the automatic shutdown device will flash for 30 seconds, then press the power button will delay the switch time 5 minutes..

## 2. Battery Voltage Check

After the power is turned on, if the LCD shows the battery voltage low symbol “”, it indicates that the battery is running low. Please replace the battery. Sufficient battery power to ensure the accuracy of the measurement.

## 3. Resistance Current or Grounding Voltage Test



**When the user thinks that the grounded value does not conform to the normal, you can use a random calibration ring to check whether the clamp meter is normal. The check ring has two resistances of 1  $\Omega$  and 10  $\Omega$ .**

After the power-on self test is completed, the large middle digit

shows “OL Ω” and resistance measurement can be performed. At this point, withhold the trigger, open the jaws, clamp the circuit under test, and read the resistance value.

The resistance and ground leakage can be measured at the same time. Press the “MODE” button after power on to switch the “resistance + current” mode.

The large middle digit shows "OL Ω", indicating that the measured resistance exceeds the upper limit of the clamp meter.

The middle large number shows "L0.01 Ω", indicating that the measured resistance exceeds the lower limit of the clamp meter.

In the “resistor + current” mode, the current value is displayed at the lower right of the display, such as “0.00mA”. If you need to measure the current, switch to this mode and read the current value directly.

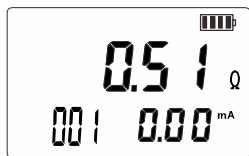

Resistance +Current mode:

The measured resistance loop resistance is 0.51 Ω.

The number of save groups is 1 ,the measured loop current is 0.00mA.



## 4. Alarm Settings

After power on, short press "**AL**" key to turn on or off the alarm function, long press "**SET**" key to set the resistance alarm value, press the "**AL**" key and "**MEM**" key to change the current size, short press "**MODE**" key to switch Alarm mode, long press "**SET**" key to save and exit. When the measured resistance is greater than the alarm critical setting and the alarm is turned on, the meter flashes the "••)" symbol and issues a "beep-beep-beep--" alarm sound. The maximum value of the ground resistance alarm setting is  $200\ \Omega$ . As shown below:



## 5. Date Lock

After the measurement is stable after power on, short press "**HOLD**" key to lock the current display data, save the data, and press "**HOLD**" key again to exit lock mode. As shown below:



## 6. Data Storage / Review / Delete

When the measurement is completed after power on, short press "**HOLD**" key to store data, "**MEM**" symbol flashes and automatically numbers, if the memory is full, the instrument flashes to display "**MEM**" symbol, press "**MEM**" key to enter the data review, store data reading interface "**MR**" symbol display. Press

“AL” or “SET” key to select the corresponding data of the array number with a step value of 1, and press “MEM” again to exit. See the figure below. The left figure flashes the “MEM” symbol when the data is stored. The current storage group number is 1; the middle figure is the data reference mode, and the current number of reference groups is 1.

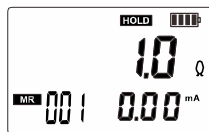
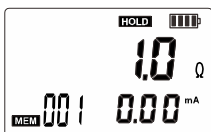

In the data review state, long press the "SET" button, then press the "POWER" button to delete the stored data

## IX. Battery Instructions

When the voltage drops to 5.0V, the battery symbol  is displayed. Please replace the battery. Low battery voltage affects measurement accuracy.

## X. Field Application

### 1. Multi-Point Grounding System

As for the multi-point grounding system (such as electricity transmission tower grounding system, grounding cable communications systems, certain buildings, etc.), They usually



pass the overhead ground wire (cable shielding layer) connected to form a grounding system. See below. As the Meter is in the above measurement, its equivalent electric circuit is shown in the figure below:

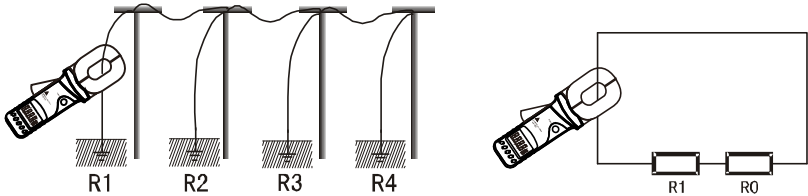

Where:  $R_1$  is the target grounding resistance.

$R_0$  is the equivalent resistance of the other entire tower grounding resistances paralleled.

Although strictly on the theoretical grounding, because of the existence of so-called "mutual resistance",  $R_0$  is not the usual parallel value in the sense of electrical engineering (slightly higher than its IEC parallel output value). But because a tower-grounding hemisphere was much smaller than the distance between the towers, and with a great number of locations after all,  $R_0$  is much smaller than  $R_1$ . Therefore, it can be justified to assume  $R_0=0$  from an engineering perspective. In this way, the resistance we measured should be  $R_1$ .

Times of comparing tests in different environments and different occasions with the traditional method proved that the above assumption is entirely reasonable.

## 2. Limited Point Grounding System

This is also quite common. For example, in some towers, five towers are linked with each other through overhead ground wire; Besides, the grounding of some of the buildings is not an independent grounding grid, but several grounding bodies connected with each other through the wire.

Under such circumstances, the above  $R_0$  regarded as 0, will yield more error on the results of the measurement.

Due to the same reasons mentioned above, we may ignore the impact of the mutual resistance; and the equivalent resistance of the grounding resistance paralleled is calculated by the usual sense. Thus, for the grounding system of  $N$  ( $N$  is smaller, but larger than 2) grounding bodies, it can offer  $N$  equations:

$$R_1 + \frac{1}{\frac{1}{R_2} + \frac{1}{R_3} + \dots + \frac{1}{R_N}} = R_{1T}$$

$$R_2 + \frac{1}{\frac{1}{R_1} + \frac{1}{R_3} + \dots + \frac{1}{R_N}} = R_{2T}$$

.

.

.

$$R_N + \frac{1}{\frac{1}{R_1} + \frac{1}{R_2} + \dots + \frac{1}{R_{(N-1)}}} = R_{NT}$$

Where:  $R_1$ 、  $R_2$ 、 ..... $R_N$  are grounding resistances of  $N$  grounding bodies.

$R_{1T}$ 、  $R_{2T}$ 、 ..... $R_{NT}$  are the resistances measured with the Meter in the different grounding branches.

It is nonlinear equations with  $N$  unknown numbers and  $N$  equations. It indeed has a definite solution, but it is very difficult to solve the issue artificially, even impossible when  $N$  is larger.

Therefore, you're expected to buy the Limited-Point Grounding System Solution software produced by our company. Users can use the office computer or notebook computer to carry out solutions.

In principle, in addition to ignoring the mutual resistance, this method does not have the measurement error caused by neglecting  $R_0$ .

However, users need to pay attention to that: in response to the number of the grounding bodies mutually linked in your grounding system, it is necessary to measure the same number of the testing values for calculating of the program, not more or less. And the program would output the same number of grounding resistance values.

### **3. Single-Point Grounding System**

From the measuring principle, EARTH TESTER series Meter can only measure the loop resistance, and the single-point grounding is not measured. However, users will be able to use a testing line very near to the earth electrode of the grounding system to artificially create a loop for testing. The following presented is two

kinds of methods for the single-point grounding measurement by use of the Meter. These two methods can be applied to the occasions beyond the reach of the traditional voltage-current testing methods.

**(1) .Two-Point Method**

As shown in the figure below, in the vicinity of the measured grounding body  $R_A$ , find an independent grounding body of better grounding state  $R_B$  (for example, near a water pipe or a building).  $R_A$  and  $R_B$  line will connect to each other using a single testing line.

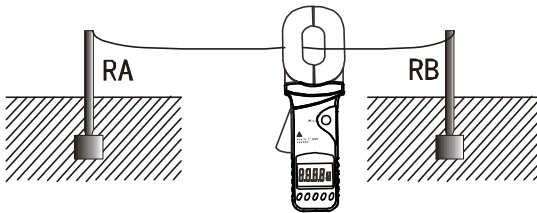

As the resistance value measured by the Meter is the value of the series resistance from the testing line and two grounding resistances.

$$R_T = R_A + R_B + R_L$$

Where:  $R_T$  is the resistance value measured with the Meter.

$R_L$  is the resistance value of the testing line.

Meter can measure out the resistance value by connecting the test lines with both ends.

So, if the measurement value of the Meter is smaller than the allowable value of the grounding resistance, then the two grounding bodies are qualified for grounding resistance.

## (2) Three-Point Method

As shown in the figure below, in the vicinity of the measured grounding body  $R_A$ , find two independent grounding bodies of better grounding state  $R_B$  and  $R_C$ .

First, link  $R_A$  and  $R_B$  with a test line; use the Meter to get the first reading  $R_1$ .

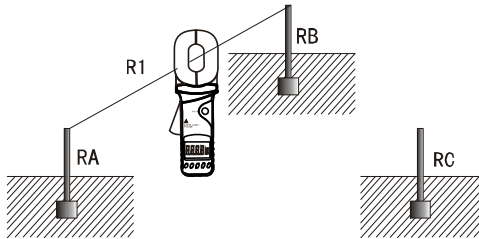

Second, have  $R_B$  and  $R_C$  linked up, as shown in the following figure. Use the Meter to get the second reading  $R_2$ .

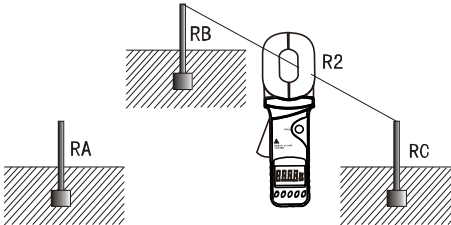

Third, have  $R_C$  and  $R_A$  linked up, as shown in the following figure. Use the Meter to get the third reading  $R_3$ .

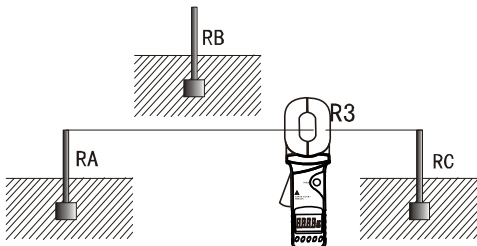

In the above three steps, the reading measured in each step is the value of the two series grounding resistance. In this way, we can easily calculate the value of each grounding resistance:

$$\text{From: } R_1=R_A+R_B \quad R_2=R_B+R_C \quad R_3=R_C+R_A$$

$$\text{We get: } R_A= (R_1+R_3-R_2) \div 2$$

This is the grounding resistance value of the grounding body  $R_A$ . To facilitate the memory of the above formula, these three grounding bodies scan be viewed as a triangle; then the measured resistance is equivalent to the value of the resistance values of the adjacent edges plus or minus resistance value of the opposite sides, and divided by 2.

As the reference points, the grounding resistance values of the other two grounding bodies are:

$$R_B=R_1-R_A$$

$$R_C=R_3-R_A$$

## XI . Accessories

Earth Tester	1PC
Battery	5th alkaline battery 4PCS
Test Loop	1PC
Manual Certificate	1 SET
Carrying Case	1PC

The contents of this user manual cannot be used as a reason to use the product for special purposes.

The company is not responsible for other losses caused by the use

The company reserves the right to modify the contents of the user manual. Any changes will be made without further notice



GuangZhou ZhengNeng Electronics Technology Co.

Address: 2F, No.15 Baoshu Road, Taihe, Baiyun District, Guangzhou,

Guangdong, China

Toll-free call: 4000-1515-38

Tel: 86-20-36544172

Fax: 86-20-37319075

Post: 510540

Website: [www.znel.e.com](http://www.znel.e.com)