

Insulation Resistance Tester(10KV)

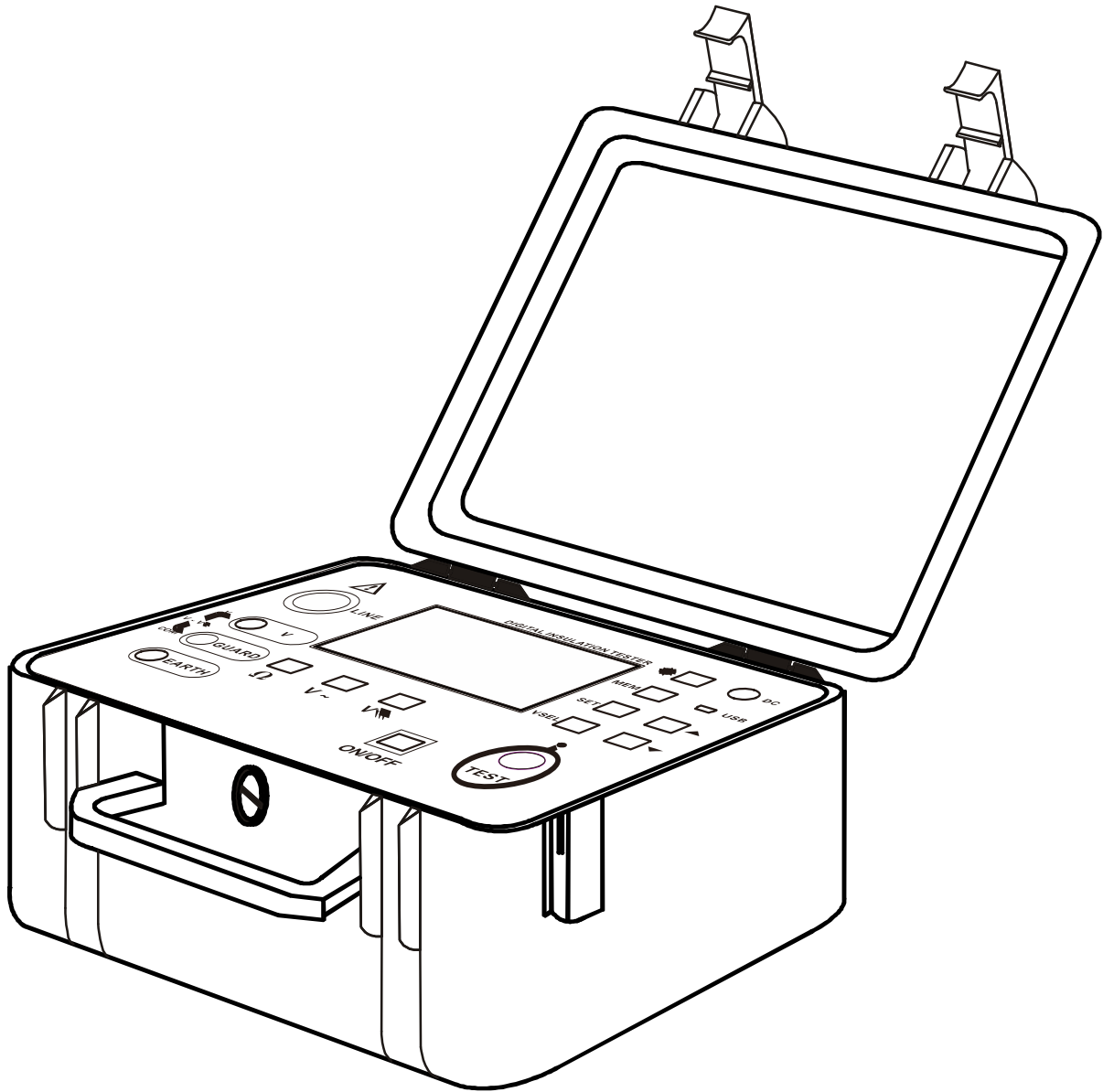

ES3035E USER MANUAL

.....
Guangzhou Zhengneng Electronic Technology Co.,Ltd.



CONTENT

I. Safety Precautions and Procedures.....	3
II. Introduction.....	4
III. Rang and Accuracy.....	5
IV .Technical Specifications.....	6
V. Structure	8
VI.Measuring Principle.....	9
VII.Operation Method.....	9
1. Power On/Off.....	9
2. Battery Voltage Check.....	9
3. DC Voltage Test.....	9
4. AC Voltage Test.....	10
5. Insulation Resistance Test.....	10
6. GUARD Use of Protective Wires.....	12
7. Polarization Index (PI) and Absorption ratio(DAR)	12
8. Backlight Control	15
9. Alarm Setting.....	15
10. Data Lock/Storage.....	16
11. Data Review/Delete.....	16
VIII. Battery Description.....	17
IX. Accessories.....	17

I.Safety Rules and Precautions

Thank you for purchasing our company's digital high-voltage insulation resistance meter. Before you use this instrument for the first time, in order to avoid possible electric shock or personal injury, please be sure to read and strictly observe the safety rules and precautions listed in this manual . .

In any case, the use of this instrument should pay special attention to safety.

- u The tester is conforming to IEC61010 on design, production and test.
- u Under any circumstance, it shall pay special attention on safety in use of this tester.
- u Please don't use high-frequency signal generators like mobile phone and etc. to avoid error during measuring.
- u Pay attention to words and symbols stick on the Tester.
- u It shall make sure that tester and accessories are in good condition before use; it can be used only when there is no damaged, naked or broken part in testing wires or insulation layer.
- u During measurement, it is forbidden to touch bare conductors and circuit under measurement.
- u Confirm that connector plug of lead has been inserted in the tester interface closely.
- u Please don't impose over 600V A.C. or D.C. voltage on the part between testing end and interface. Otherwise, it may have damage on the tester.
- u Please don't measure in an inflammable place. The flame sparkle maybe cause explosion.
- u During usage of tester, please stop using it when exposed metal is caused by broken enclosure or testing wires.
- u Please don't keep or store the tester in the spot with high-temperature and moisture, or condensation, and under direct daylight radiation for a long time.
- u For replacing battery, please confirm testing wire has moved apart the meter, and FUNCTION SWITCH rotary switch is in "OFF" position.
- u Please put the used batteries in appointed collection place.
- u When replacing the battery with the meter, make sure that the test line has been removed from the meter and the meter is turned off.
- u When the meter displays battery low voltage symbol  , should charge in time, otherwise it will lead to ground error.
- u Do not charge or perform data transmission during the measurement process.
- u Do not make measurements when the battery cover is open and during thunder.
- u Pay attention to measuring range and usage environment stipulated for the Tester.
- u This measuring device is only to be used, disassembled, adjusted and repaired by qualified personnel with authorization.
- u When it may cause hazard by continuous use for the reason of the Tester itself, it shall immediately stop using it and deposit it at once, leaving it for disposal by authorized agency.
- u For risk of danger icon in manual  , users must perform safety operations

strictly in compliance with the manual content.

- ⊔ The instrument output high voltage, please be sure to connect the test line hand to leave the test line before pressing the test button to test, otherwise there is danger of electric shock.
- ⊔ After the test is completed, wait for one minute for the discharge to complete before removing the test line. When removing the test line, first remove the test line of the meter and then collect the test line.

II. Introduction

Digital insulation resistance meter also known as megohmmeter, high voltage insulation resistance tester, etc., for the insulation resistance test. The instrument has a large LCD screen gray backlight display, data storage, data access, alarm, automatic shutdown and other functions. At the same time, it also has the function of measuring AC voltage absorption ratio and polarization index of DC voltage. The machine is beautiful and upscale, has a wide range, high resolution, convenient operation, easy to carry, accurate, reliable, stable performance, strong anti-interference ability. Moreover, it has a shockproof, dustproof, moisture-proof structure and is a commonly used and indispensable instrument for telecommunications, electricity, meteorology, computer rooms, oil fields, electromechanical installation and maintenance, and industrial enterprises that use electricity as industrial power or energy. It is suitable for measuring the resistance value of various insulating materials and the insulation resistance of transformers, motors, cables and electrical equipment.

Digital insulation resistance meter consists of medium and large scale integrated circuits. The output power of the watch is large, and the output voltage level is a lot (with 6 voltage levels). Rated insulation test voltage range 250V ~ 10kV, insulation resistance measurement range $0.01M\Omega \sim 1000G$

Ω . DC voltage measurement range 0 ~ 1000V, AC voltage measurement range 0 ~ 750V

III. Measuring Range and Accuracy

Test Function	Output Voltage	Measure Range	Accuracy	Resolution
Insulation Resistance	250V(±10%)	0~10M Ω	±3%rdg±5dgt	0.01M Ω
		10~100M Ω		0.1M Ω
		100~1000M Ω		1M Ω
		1G~10G Ω	±5%rdg±5dgt	0.01G Ω
	500V(±10%)	0~10M Ω	±3%rdg±5dgt	0.01M Ω
		10~100M Ω		0.1M Ω
		100~1000M Ω		1M Ω
		1G~10G Ω	±5%rdg±5dgt	0.01G Ω
	1000V(±10%)	0~20M Ω	±3%rdg±5dgt	0.01M Ω
		20~200M Ω		0.1M Ω
		200~2000M Ω		1M Ω
		2G~20G Ω	±5%rdg±5dgt	0.01G Ω
	2500V(±10%)	0~2000M Ω	±3%rdg±5dgt	1M Ω
		2000M Ω ~20G Ω	±5%rdg±5dgt	0.01G Ω
		20G Ω ~200G Ω	±20%rdg±10dgt	0.1G Ω
	5000V(±10%)	0~2000M Ω	±3%rdg±5dgt	1M Ω
		2000M Ω ~20G Ω	±5%rdg±5dgt	0.01G Ω
		20G Ω ~200G Ω	±20%rdg±10dgt	0.1G Ω
		200G Ω ~1000G Ω	±20%rdg±10dgt	1G Ω
	10kV(±10%)	0~2000M Ω	±3%rdg±5dgt	1M Ω
2000M Ω ~20G Ω		±5%rdg±5dgt	0.01G Ω	
20G Ω ~200G Ω		±20%rdg±10dgt	0.1G Ω	
200G Ω ~1000G Ω		±20%rdg±10dgt	1G Ω	

Remark: Common electrical unit conversion

1 T Ω (Tera ohm) =1000G Ω =10¹² Ω

1 G Ω (Giga ohm) =1000M Ω =10⁹ Ω

1 M Ω (Mega ohm) =1000K Ω =10⁶ Ω

Test Function	Measure Range	Accuracy	Resolution
DC Voltage	DC 0.0V~1000V	$\pm 1.5\%rdg \pm 3dgt$	0.1V
AC Voltage	AC 0.0V~750V	$\pm 1.5\%rdg \pm 3dgt$	0.1V

IV .Technical Specifications

Function	Insulation resistance test, voltage test
Base conditions	23°C±5°C, below 75%rh
Rated voltage(V)	250; 500; 1000; 2500; 5000V; 10KV
Test Voltage(V)	rated voltage× (1±10%)
Insulation Resistance Range (G Ω)	0.01M Ω ~ 1000G Ω
Insulation Resistance Insulation	0.01M Ω
DC Voltage Range	0~1000V
DC Voltage resolution	0.1V
AC Voltage Range	0~750V
AC Voltage resolution	0.1V
Output short-circuit Current	≥3mA(5KV)
Absorption Ratio and Polarization Index Measurement	Have
Power Supply	12V rechargeable battery

Backlight	Controllable gray screen backlight, suitable for use in dim places
Display mode	4-bit large LCD display, gray screen backlight
LCD display size	108mm×65mm
Instrument size	L/W/H: 277.2mm×227.5mm×153mm
USB interface	With USB interface, software monitoring, storage data can be uploaded to the computer, save the print
Communication Line	USB communication line 1PC
Test Line	High voltage red 3meter, high voltage test line black 1.5meter, green 1.5meter
Data Storage	500 groups, "FULL" symbol indicates that storage is full
Data Review	Data review function: "MR" symbol display
Overflow Display	Exceed measurement range overflow function: "OL" symbol display
Alarm Function	Alarm when the measured value exceeds the alarm setting value
Power Consumption	Standby: 30mA Max(backlight off)
	Turn on backlight: 42mA Max
	Measure: 300mA Max(backlight off)
Instrument weight	2720g(including battery)
Battery voltage	When the battery voltage is low, low battery symbol "  "will display
Automatic shut-down	automatic shutdown after 15 minutes boot
Insulation Resistance	≥50MΩ(between Measuring line and housing)
Pressure Resistance	AC3kV/50Hz 1min

Working Temperature and Humidity	-10°C~+50°C<85%RH
Storage Temperature and Humidity	-15°C~+55°C<90%RH
Suitable for Safety Regulations	IEC61010-1、IEC1010-2-31、IEC61557-1,5、IEC60529(IP54) pollution grade 2、CAT III 300V

V. Structure

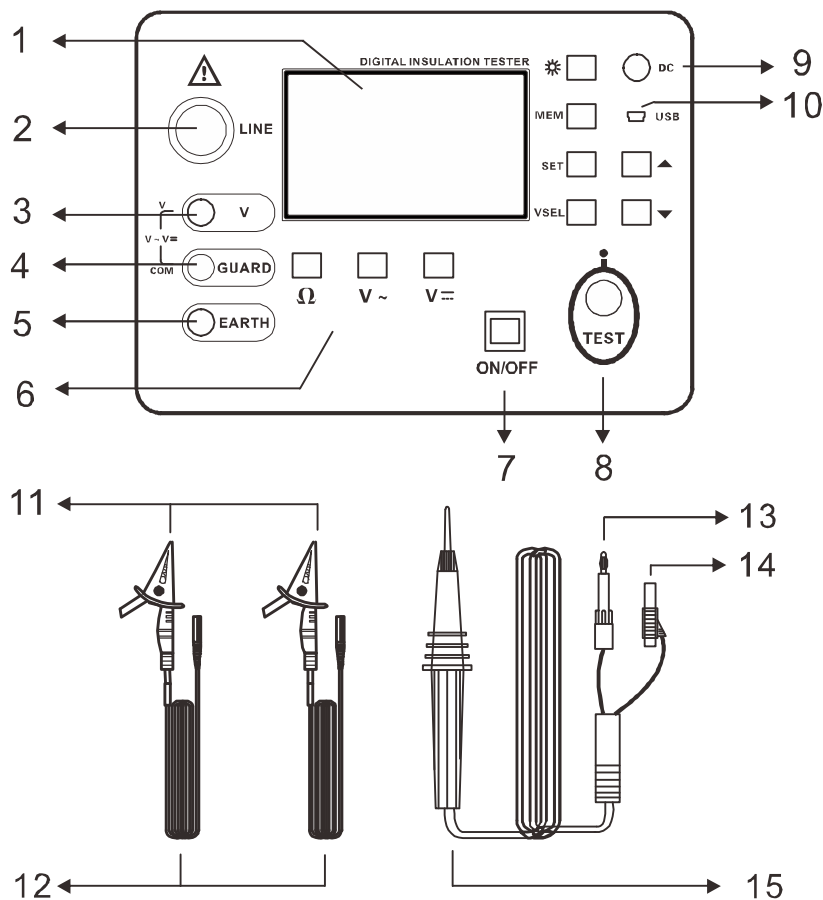

1. LCD display screen
2. LINE interface
3. V interface
4. GUARD interface
5. EARTH interface
6. Function button area
7. Power on/off button
8. Test button
9. changer interface
10. USB interface
11. Security Alligator Clip
12. Test line (green , black each 1PC)
13. High voltage test terminal banana plug into LINE interface
14. Shielded cable connector plugged into GUARD interface (no connection required without this connector)
15. High voltage test line

VI.Measuring Principle

Insulation resistance measurement uses a voltage generator to generate a voltage, V , applied across the resistor, measuring the current I flowing across the resistor, and calculating the ground resistance value R according to the formula $R=V/I$.

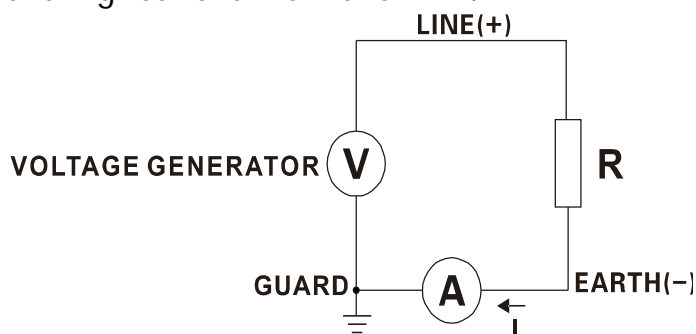

$$R = V / I$$

VII.Operation Method

1. Power On/Off

Press the POWER button to turn the switch on and off. After the power is turned on, “APO” is displayed in the lower corner. When it is not in operation, it will automatically shut down after 15 minutes.

2. Battery Voltage Check

After powering on, if the LCD shows a low battery voltage sign “”, it indicates that the battery is running low. Please charge in time.

Sufficient battery power to ensure measurement accuracy

3. DC Voltage Test



Press the button  to switch to the DC voltage test mode, connect the green test lead to the V terminal, the black test lead to the COM, and the LCD displays the real-time DC voltage value.

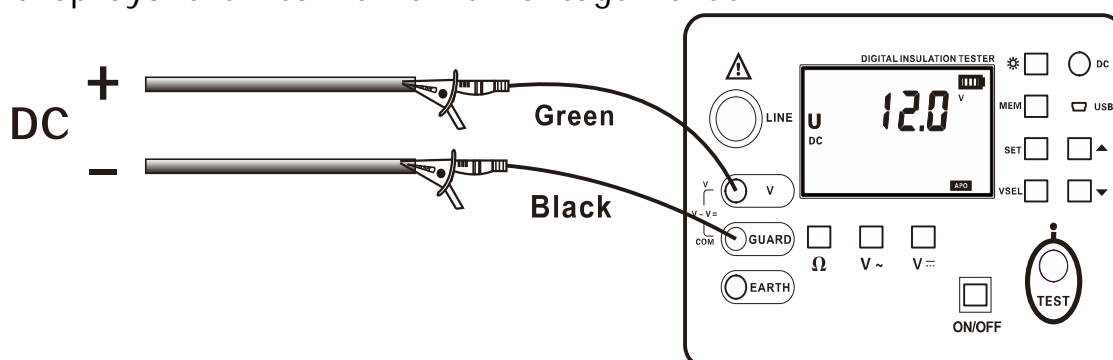

4. AC Voltage Test

	<p>Input instrument AC voltage cannot exceed 750V.</p>
---	--

When measuring, turn the rotary switch to the gear $V \sim$ position, connect the green lead to the V terminal, the black lead to the COM, and the LCD displays the real-time AC voltage value.

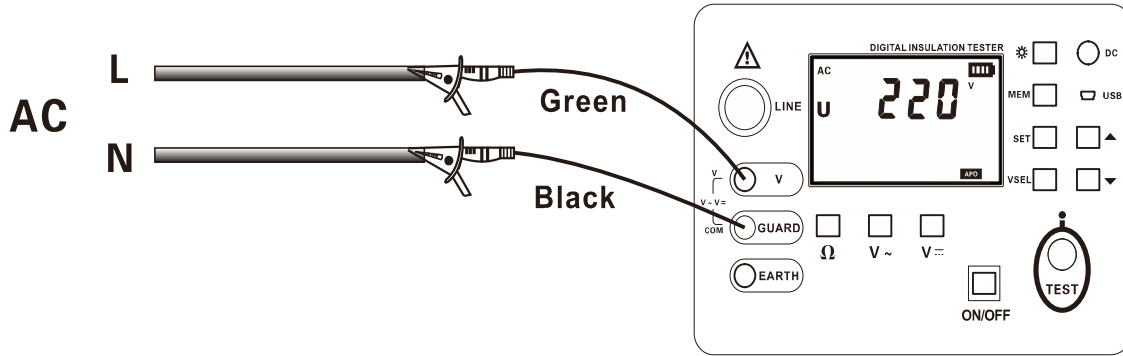

5. Insulation Resistance Test

	<p>Insulation resistance test can only be carried out on an uncharged circuit. Before testing, check whether the test circuit wiring is in good condition and whether the circuit under test is energized. If the circuit is live, it may damage the instrument and affect the measurement accuracy.</p>
	<p>Must wear high-voltage insulating gloves to operate.</p>
	<p>In the insulation resistance range, press the test switch to generate high voltage in the test line head and in the circuit under test. Please be careful to avoid touching.</p>
	<p>Be sure to connect the grounding wire (black) to the grounding port of the circuit under test.</p>
	<p>Do not touch the circuit immediately after testing. The stored charge may cause electric shock.</p>

	Do not remove the test lead immediately. Wait until the discharge is complete before touching the circuit under test.
	In order to ensure the measurement accuracy, do not twist the test lines together.

Guaranteed temperature and humidity of the insulation resistance accuracy

Insulation resistance range	Guaranteed the humidity value of the insulation resistance accuracy	Guaranteed temperature of the insulation resistance accuracy
0 Ω - 100MΩ	<85% RH(No condensation)	23°C ± 5°C
101MΩ - 20GΩ	<75% RH(No condensation)	
21GΩ - 200GΩ	<65% RH(No condensation)	

Insulation resistance test can only be carried out on an uncharged circuit. Before testing, check that the test leads are good and confirm that the circuit under test is uncharged.

Turn the rotary switch to Ω gear, then press **VSEL** to select the voltage value to be tested.

One end of the ground wire (black) is connected to the instrument connection EARTH and the other end is connected to the ground end of the circuit under test. One end of the high-voltage rod test line (red) is connected to the other end of the instrument LINE and the head is in contact with the circuit under test. If the test has a green branch line as a shielded line, the accuracy of connecting the GUARD port during testing is better. If the matching test line does not carry this line, it does not need to be connected. As shown in the figure, press the **TFRT** test button. The LCD shows

the measured value. Read the insulation resistance value after the measured value is fixed.

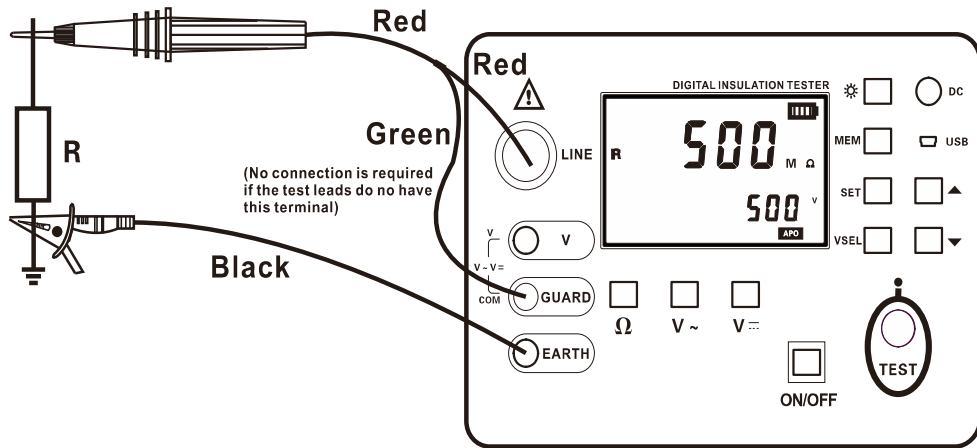

6. GUARD Use of Protective Wires

When the insulation resistance of the cable is measured, the leakage current of the covered surface passes through the interior of the insulator and the current converges, resulting in an error in the insulation resistance value. In order to avoid this phenomenon, as shown in the figure below, use the protection wire (any conductive bare wire) to flow the leakage current through the part. After connecting to the protection port, the leakage current does not flow through the insulator and the insulator can accurately measure the insulation resistance. Please use the protection test cable of the accessory to connect the protection port.

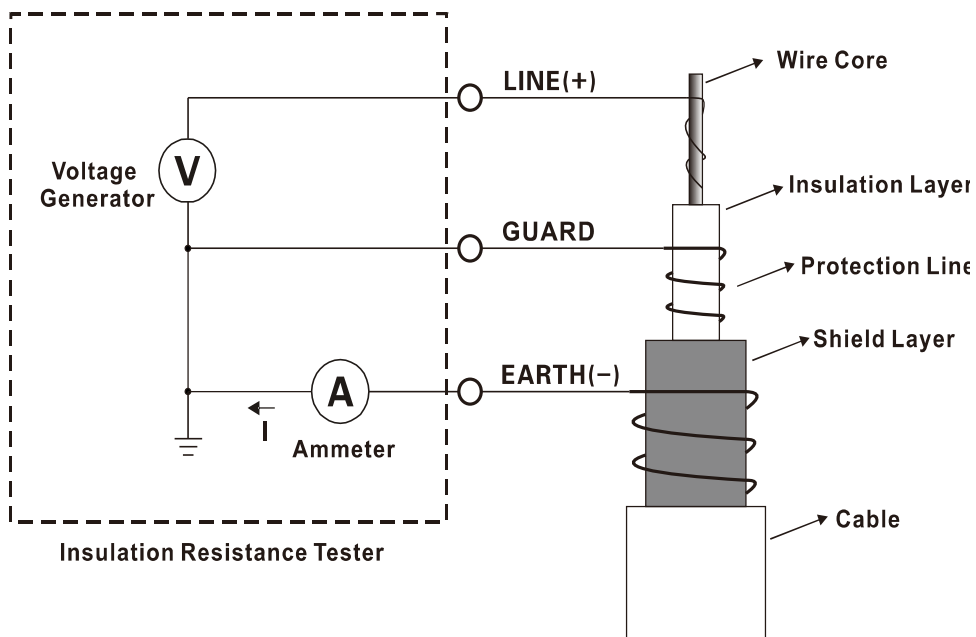

7. Polarization Index (PI) and Absorption ratio(DAR)

7.1The function of Polarization index (PI) and Absorption ratio(DAR):

The Polarization Index (PI) and Absorption Ratio (DAR) are tests to check whether the leakage current of the insulator has increased. The leak current did not increase while confirming the application time. The instrument automatically calculates the polarization index PI and the absorption ratio DAR. As a judgement of the insulation performance, both the polarization index PI and the absorption ratio DAR indicate the change in the insulation resistance over a period of time after the measured object withstands the measured voltage.

7.2 The difference between Polarization index (PI) and Absorption ratio (DAR):

For general insulation tests, such as housing insulation, tool handles, etc. can generally be tested in a relatively short period of time to increase the leakage current with the increase of the voltage application time, so generally can be tested with a short time test, the short-term insulation resistance ratio DAR is called the absorption ratio (see the following formula for the specific test time), but for the large-capacity and long-term absorption process, such as transformers, generators, cables, capacitors and other electrical equipment, sometimes the absorption ratio (DAR) is not enough to reflect the whole process of absorption, and the insulation resistance ratio can be used for a longer time, that is, the ratio between the insulation resistance (R10min) at 10 minutes and the insulation resistance (R1min) at 1 minute describes the entire process of insulation absorption, and PI is called the polarization index.

The PI and DAR values are calculated by the following formula:

$$\text{PI(Polarization Index)} = \frac{R_{10 \text{ Min}}}{R_{1 \text{ Min}}}$$

$$\text{DAR (Absorption ratio)} = \frac{R_{60 \text{ Sec}}}{R_{15 \text{ Sec}}}$$

$$\text{DAR (Absorption ratio)} = \frac{R_{60 \text{ Sec}}}{R_{30 \text{ Sec}}}$$

- Remark:**
- 1: R10Min= resistance value measured by the voltage applied for 10 minutes
 - 2: R1Min=R60Sec=the resistance value measured by the voltage applied for 1 minutes
 - 3 : R30Sec=It is the resistance value measured by the voltage applied for 30 seconds
 - 4: R15Sec=It is the resistance value measured by the voltage applied for 15 seconds
 - 5: DAR calculation time can choose 15 seconds or 30 seconds

7.3 Polarization index (PI) and Absorption ratio (DAR) Test

The Polarization Index (PI) and Absorption Ratio Test (DAR) can only be performed on uncharged circuits. Before testing, check that the test leads are good and confirm that the circuit under test is charged or not.

Turn the rotary switch to Ω gear, then press **VSEL** to select the voltage value to test.

Press the **SET** key to set the corresponding mode. The LCD shows "10:01m" as the polarization index mode in the lower left corner of the LCD, "60:15S" as the absorption mode 15 second mode, and "60:30S" as the absorption mode 30 second mode. Small numbers do not show anything for the insulation resistance measurement mode.

One end of the ground wire (black) is connected to the instrument connection EARTH and the other end is connected to the ground end of the circuit under test. One end of the high-pressure rod test line (red) is connected to the other end of the instrument LINE and the head is in contact with the circuit under test, and the **TFRT** test key is pressed. The LCD displays the measured value. After the measured value is fixed, the absorbance or polarization index can be read.

After the test is completed, press "▲" to view the divisor of the absorption ratio or polarization index value (such as the value of 60S in "60:15S" mode). Press "▼" to view the dividend of the absorption ratio or polarization index value (such as the value of 15S in "60:15S" mode). Press "▲" or "▼" again to return.

7.4 Polarization Index (PI) and Absorption Ratio (DAR) Applications:

In engineering, insulation resistance and absorption ratio (or polarization index) can reflect the degree of moisture in the insulation of generators, oil-immersed power transformers and other equipment. The value of the absorption ratio (or polarization index) decreases after the insulation is wet (see Figure 1), so it is an important indicator of whether the insulation is affected by moisture.

It should be pointed out that sometimes the insulation has obvious defects (for example, the insulation breaks down under high pressure), and the absorption ratio or polarization index value is still good. The absorption ratio or polarization index cannot be used to find other local insulation defects other than moisture and dirt.

。

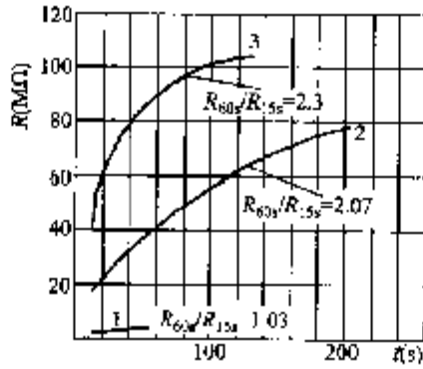

1-Befor drying,15 degree Celsius; 2-When the end of drying, 73.5 degree Celsius
3-After running 72h, and cooled to 27 degree Celsius

Figure 1 The relationship between the insulation resistance R of a generator and the time t

Polarization Index Reference Judgment Value:

Polarization Index	Above 4	4~2	2.0~1.0	Below 1.0
Judge	The best	Good	Need to pay attention	Bad

Absorption ratio reference judgment value:

Absorption ratio	Above 1.4	1.25~1.0	Below 1.0
------------------	-----------	----------	-----------

8. Backlight Control

After power on, press “☀” key to turn the backlight on or off, and the backlight function is suitable for dim places. The default backlight turns off every time you turn it on.

9. Alarm Settings

After power on, long press “☀” to turn on and off the alarm function. Long press “**SET**” key to set the resistance alarm value. Press “▲” or “▼” key to change the current digit size, then press “**SET**” key to save and exit. When the measured voltage value is greater than the alarm critical set value or the insulation resistance value is less than the alarm critical set value and the alarm function is turned on, the instrument flashes the “☹)” symbol and issues a “beep-beep-beep--” alarm sound. The maximum value of the voltage alarm setting is 600V, and the maximum value of the ground

resistance alarm setting is 9999MΩ. As shown below



10. Data Lock/Storage

After the measurement is completed, short press "MEM" key to lock the current display data, and automatically serial storage. If the storage is full, the instrument displays the "FULL" symbol. As shown in the following figure: the measured data is 1258mΩ, and the "MEM" display is stored as the third set of data.

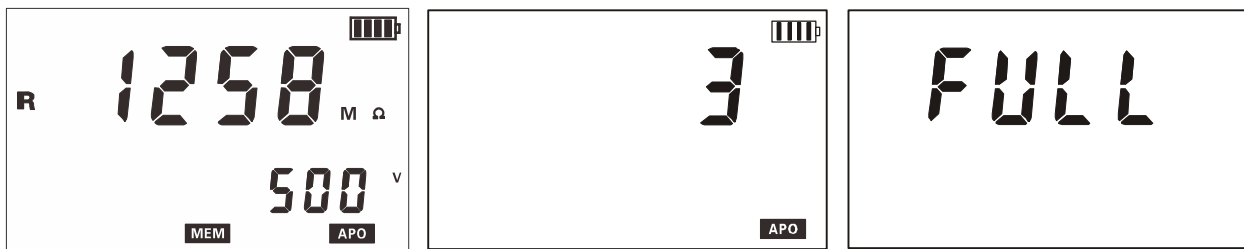

11. Data Review/Deletion

After booting or measuring, press the "MEM" button (more than 3 seconds) to enter the data lookup, and store the data read interface "MR" symbol display. Press the "▲" or "▼" key to select the data corresponding to the array number with a step value of 1, press "▲" or "▼" to select the array number with a step value of 10, and press "MEM" to exit. See below

In the following figure, the number 3 is the current number of groups and 6 is the total number of groups. If there is no stored data, LCD display "NULL", see the figure below.

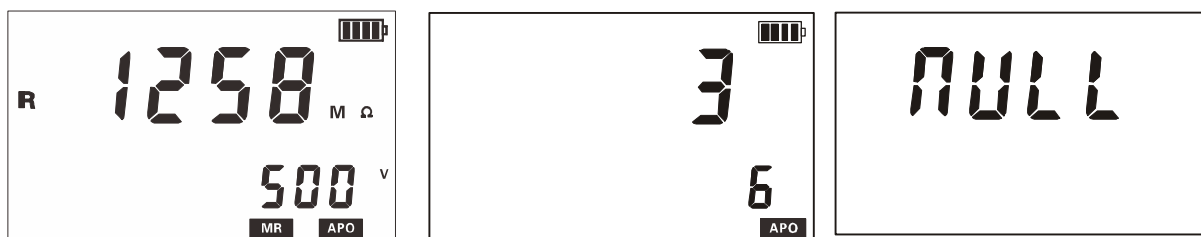

In the data review state, press and hold the “MEM” key to enter the data deletion, press “ ” or “ ” to select “NO” or “YES”, select “NO” and then press “SET” key to not return to the data review state. “YES” Press “SET” again to delete the stored data. After deletion, the following figure is displayed.



VIII. Battery Description

The instrument is powered by a 12V battery, when the battery power is reduced, when the voltage drops to 10V, the battery symbol "" is displayed. Please replace the battery in time. Low voltage affects the measurement accuracy.

IX. Accessories

Instrument	1PC
High pressure rod	1PC red
High voltage test line	2PCS (black,green each 1)
Monitoring Software CD	1PC
USB communication lineUSB	1PC
charger	1PC
Manual, certificate	1SET
Instrument box	1 个



GuangZhou ZhengNeng Electronics Technology Co.

Address: 2F, No.15 Baoshu Road, Taihe, Baiyun District, Guangzhou, Guangdong, China

Toll-free call: 4000-1515-38

Tel: 86-20-36544172

Fax: 86-20-37319075

Post: 510540

Website: www.znele.com